

Installation Instructions

RTPC Power Connection Kit for Self-Regulating and Constant Wattage Heating Cable



- RTPC Power Connection Kit Parts:**
- 1 - Molded Junction Box consisting of:
Base - Box - Lid - Hardware
 - 1 - Three Position Terminal Block
 - 1 - Mounting Screw for Terminal Block
 - 1 - Cover Gasket
 - 1 - Grommet for Self-Regulating Cable

Certifications & Approvals

- UL listed Ordinary Areas
- FM approved Ordinary Areas
- Class I, Division 2, Groups B, C, D
- Class II, Division 2, Groups F, G
- Class III, Division 2



RTPC for use only with Trasor SRL and SRME Self Regulating heating cables

GENERAL

WARNING: Hazard of Electric Shock. Disconnect all power before starting. All installations must be effectively grounded in accordance with the National Electrical Code to eliminate shock hazard.

NOTE: All electrical wiring, including GFCI (Ground Fault Circuit Interrupters), must be done according to National Electrical or local codes by a qualified person.

The RTPC Kit is used to connect base, braided (-C) and overjacketed (-CR or -CT) versions of Self-Regulating and Fluoropolymer insulated Constant Wattage Heating Cables to power.

Each kit contains enough material to make one power connection point. It is possible to connect up to three Self-Regulating or two Constant Wattage Cables in the same box. (One grommet required for each cable.)

Materials required for installation include: standard electrical cutters, screwdriver, sharp utility knife and a pipe strap (Trasor PS or equal).

Wipe inside lip of cover with a clean cloth. Remove protective backing from the gasket and affix it to the cover lip. Press firmly all around for proper adhesion.

INSTALLATION

WARNING: Hazard of Electric Shock. Disconnect all power before starting.

NOTE: These instructions are for all Self-Regulating and Constant Wattage heating cables in ordinary locations. Consult factory for installation of braided cable in hazardous locations. Not all instructions are for all cables. Each step of the instructions will have a heading in boldface stating what type of cable each instruction is intended for.

1. FOR CONSTANT WATTAGE CABLES:

Cut the cable 12 inches past the last module point (indentation in cable). **NOTE:** Cutting the cable between module points creates a non-heating cold lead. See Figure 1.

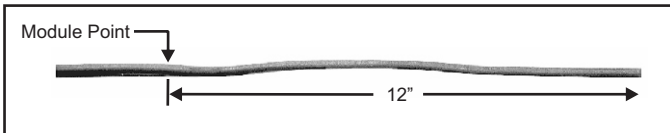

Figure 1

2. FOR CABLE WITH EXPOSED METAL BRAID (-C):

Push the braid back 12 inches on the cable. See Figure 2.

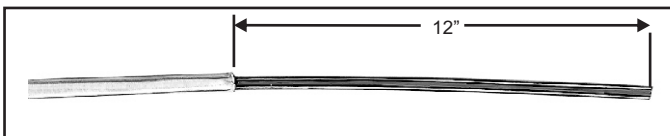

Figure 2

3. FOR ALL CABLES:

Feed the ends of the cables through the appropriate hole in the base. Allow eight (8) inches of cable to extend above the top of the base. See Figure 3.

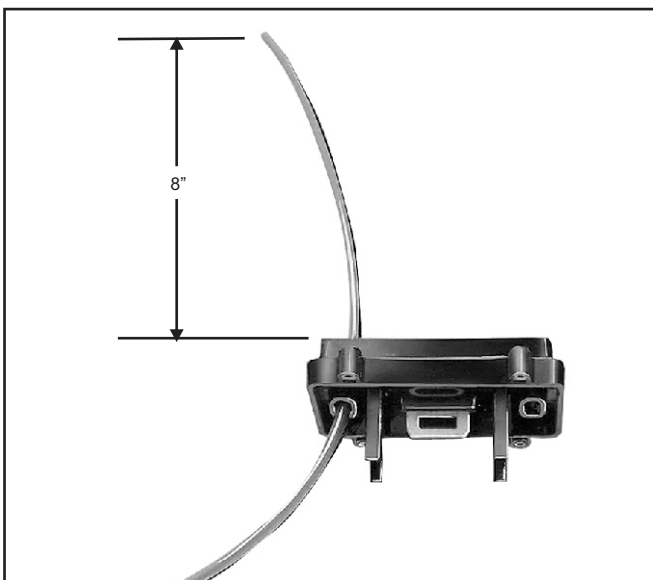

Figure 3

4. FOR ALL CABLES:

Slide cable grommet over the end of the cable and insert it into the opening in the base. Secure the base to the pipe by threading the appropriate sized pipestrap through the slot in the mounting plate. Tighten the pipestrap until the base is securely attached to the pipe. See Figure 4.

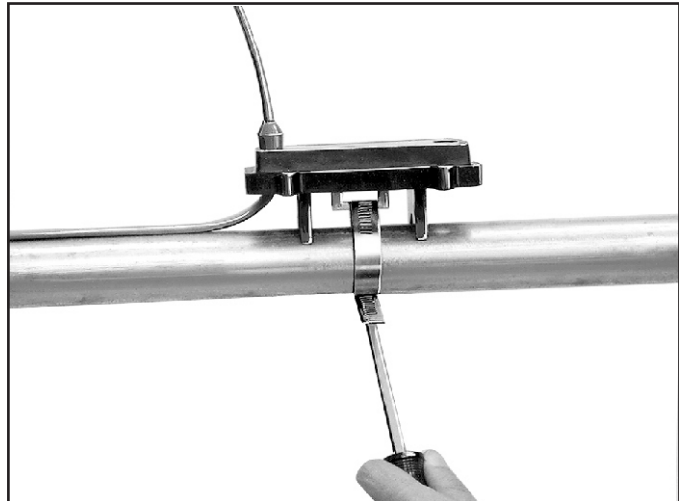

Figure 4

5. FOR OVERJACKETED CABLES (-CR or -CT):

Score the outer insulation seven (7) inches from the end of cable. Remove the jacket to expose the metal braid. See Figure 5. **WARNING: Do not damage the braid or the base cable insulation.**

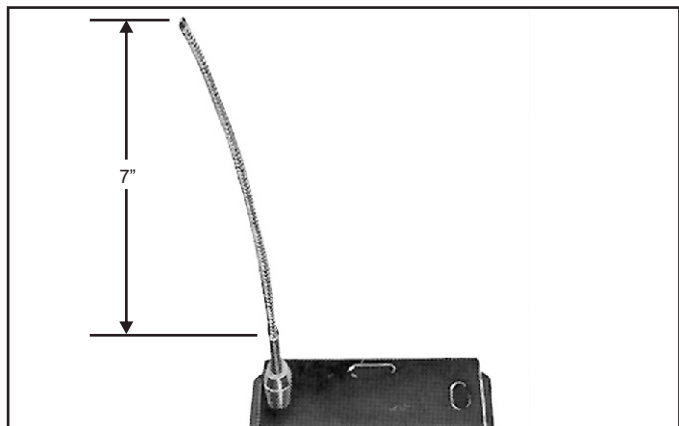

Figure 5

6. FOR ALL CABLES:

Punch out the knockouts on the bottom of the box which correspond to the openings in the base through which the heating cable passes. Be careful to punch out only those knockouts to be used. If one is mistakenly punched, blank grommets can be ordered to re-establish the water tight seal. See Figure 6.



Figure 6

INSTALLATION

7. FOR ALL CABLES:

Feed the cables through the corresponding holes in the box. Secure box to base using all four (8-32) screws. See Figure 7.

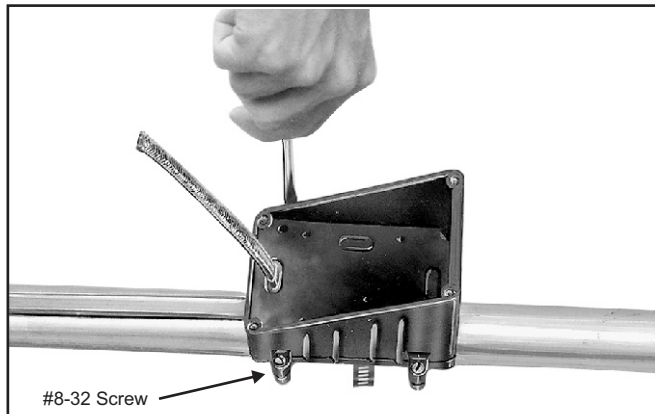

Figure 7

8. FOR OVERJACKETED CABLES:

Starting from the end of the cable, unravel 2-1/2 inches of the braid. Twist the strands together to form a pigtail. See Figure 8.

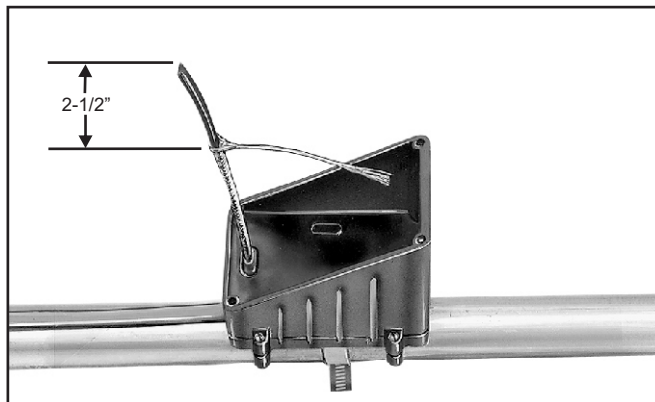

Figure 8

9. FOR SELF-REGULATING CABLES:

Using standard electrical cutters, cut a 3/4 inch long notch out of the cable between the conductor wires. Bare a 3/8 inch length of each conductor by stripping off the outside insulation and the inner black core material. See Figure 9.

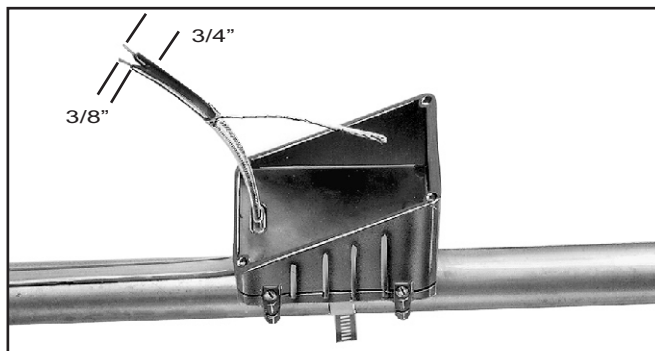

Figure 9

10. FOR CONSTANT WATTAGE CABLES:

Score the outer jacket 3/4 inch from the end of the cable and remove the jacket. Cut off the exposed nichrome wire, pushing any remainder back under the jacket. These cables have an inner layer of insulation which is also to be removed as described above. Separate the buss wires and strip off the last 3/8 inch of insulation from both buss wires. See Figure 10.

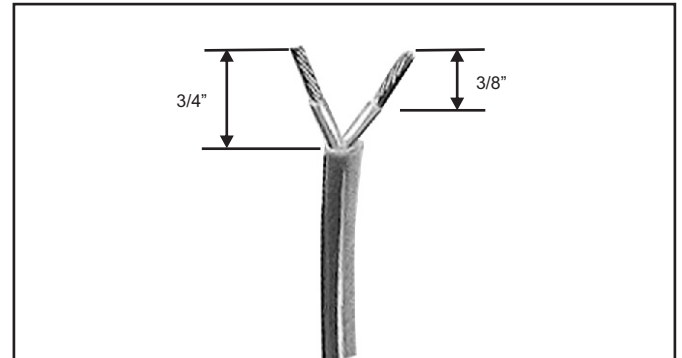

Figure 10

11. FOR ALL CABLES:

Insert the bared ends of the conductors into the openings in the terminal block. Tighten screws firmly to hold conductors in place. See Figure 11.

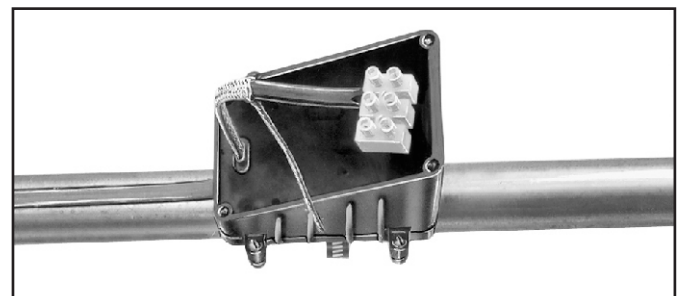

Figure 11

12. FOR OVERJACKETED CABLES (-CR or -CT):

Insert the end of the braid pigtail into the remaining opening in the terminal block. Tighten screw firmly to hold the braid in place. See Figure 12.

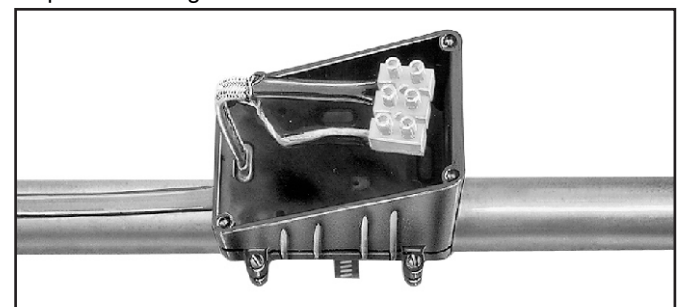

Figure 12

INSTALLATION

13. FOR ALL CABLES:

Connect conduit hub (Trasor CCH or equal) to the box. Attach conduit to hub and bring power leads into box. See Figure 13.



Figure 13

14. FOR ALL CABLES:

Strip 3/8 inch length of each conductor of the power cord. Insert the bared ends of the conductors into the corresponding openings on the unused side of the terminal block. Remember, the green (ground) wire must be opposite of the opening of the terminal block which is either empty or contains the metal braid. See Figure 14.

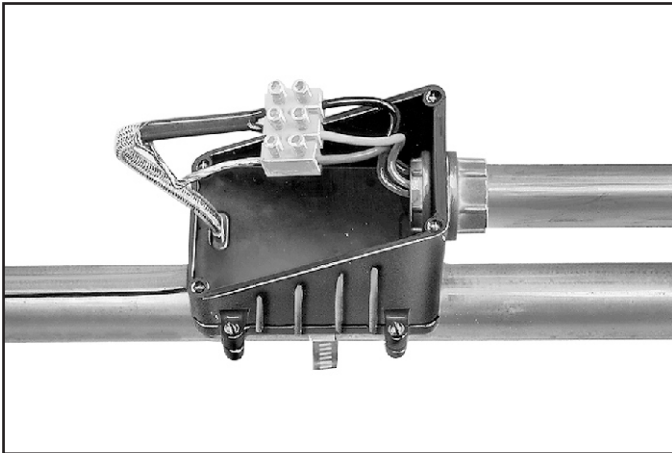

Figure 14

15. FOR ALL CABLES:

Mount terminal block to bottom of the box by driving the 6-32 self-tapping screw into the mounting hole as shown. See Figure 15.

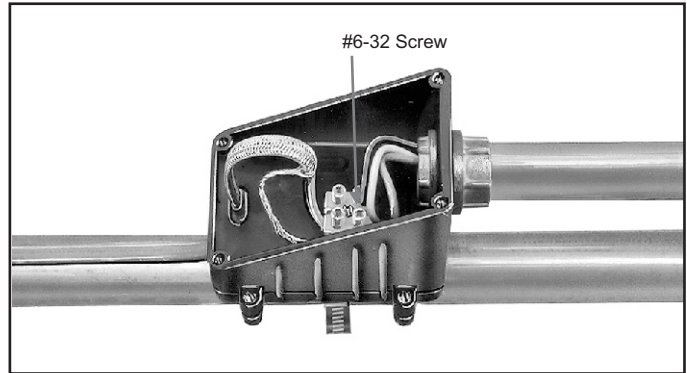

Figure 15

16. FOR ALL CABLES:

Carefully push the wires into the box. Secure the lid to box. See Figure 16.

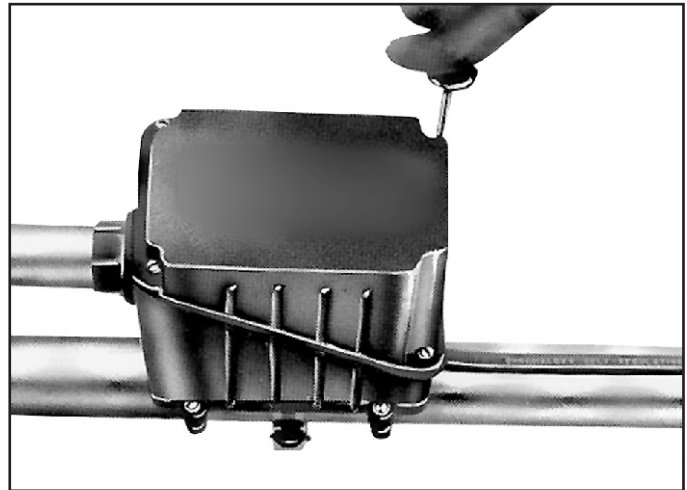

Figure 16

17. FOR CABLE WITH EXPOSED METAL BRAID (-C):

Unravel four (4) inches of braid from the cable and twist into a pigtail. **WARNING: Connect to appropriate grounding source.** See Figure 17.

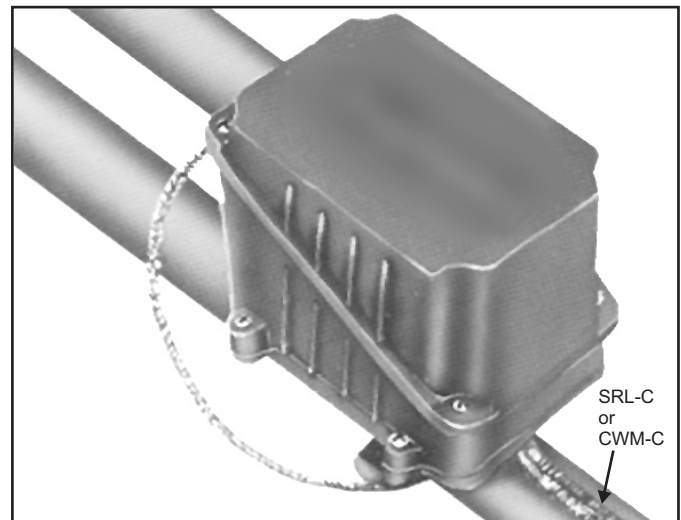

Figure 17