

# UES End Seal Kit

For Self-Regulating & Constant Wattage Heating Cables



**TRASOR**

PJ496-3  
161-562581-028  
March 2013



# UES End Seal Kit

## Self-Regulating & Constant Wattage Heating Cable Installation Instructions



Item	Qty	Description
1	1	Pipe Standoff
2	1	Self-Regulating Cable Grommet
3	1	Constant Wattage Cable Grommet
4	1	End Cap

### General

The UES End Seal kit is used for electrical termination of self-regulating or constant wattage cables. Each kit contains the terminations needed to make all electrical connections.

### Certifications & Approvals

IP66 NEMA/Type 4x  $-60^{\circ}\text{C} < \text{Ta} < +55^{\circ}\text{C}$   
 Ordinary & Hazardous Locations  
 Class I, Division 2 Groups A,B,C, & D, Zone 2 IIC  
 Class II, Division 2, Groups F & G, Class III



ITS08ATEX36059X CE0389  
 IIG Exe II T6 Ta  $-60^{\circ}\text{C}$  ti  $170^{\circ}\text{C}$   
 IECEX ITS 07.0018X  
 Exe II T6 GbTa  $-60^{\circ}\text{C}$  to  $170^{\circ}\text{C}$

### Tools Required for Kit Installation

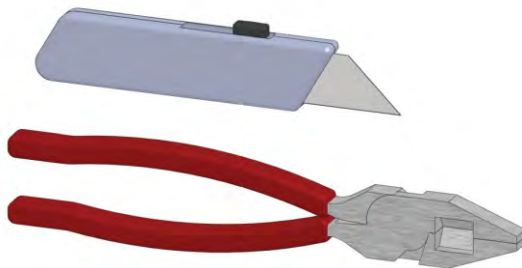

### Actual Kit Dimensions

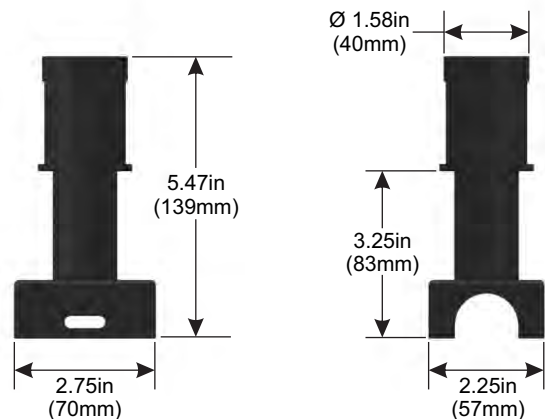

## ⚠WARNING

**HAZARD OF ELECTRIC SHOCK.** Disconnect all power before opening. All installations must be effectively grounded in accordance with the National Electrical Code to eliminate shock hazard. To avoid electrostatic discharge. Wipe with damp cloth.

## ⚠WARNING

Turn off power before removing junction box cover at all times.

## ⚠WARNING

Users should install adequate controls and safety devices with their electric heating equipment. Where the consequences of failure may be severe, back-up controls are essential. Although the safety of the installation is responsibility of the user, Trasor will be glad to assist in making equipment recommendations.

### Order Separately

#### Pipe Straps

- PS-1 - 1/2" to 3/4" pipes
- PS-3 - 1" to 3" pipes
- PS-6 - 3" to 6" pipes
- PS-18 - 6" to 18" pipes



#### Caution Labels

- EHTL-1 - Single Labels
- EHTL-5 - 5-Pack of EHTL-1

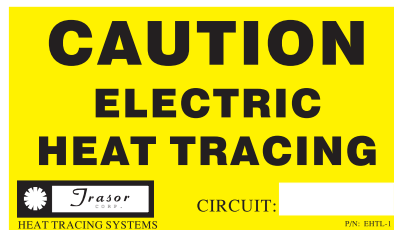

#### Fiberglass Tape

- FGT-66 - For non-SS pipes & install temp > 40F
- FGT-66S - For SS pipes or install temp < 40F



#### Small Pipe Adapter

- SPA - For mounting to pipes 1-1/2" and smaller



## Cable installation instructions: SRL, SRF, SRME, SRP CWM cable special instructions denoted by \*

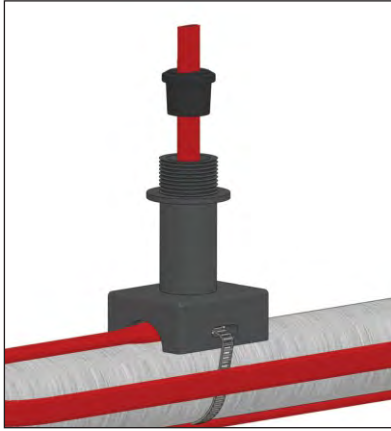

1. Insert cable without the braid through pipe standoff and grommet as shown. Attach pipe standoff to pipe with pipe straps (Trasor model PS not included). Leave braid outside of pipe standoff at grommet. For pipes smaller than 1 1/2" diameter a small pipe adapter (Trasor model SPA not included) is required.

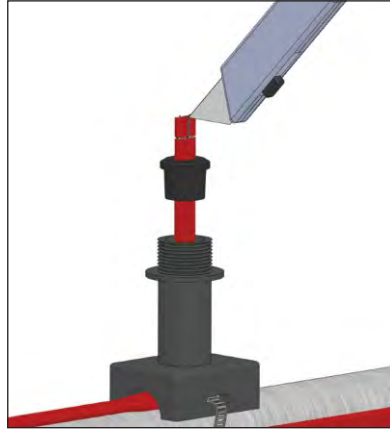

2. Score the outer insulation 1/2 inches from the end of cable. Lightly cut the outer jacket up the center to end of heating cable and remove the jacket from the cable.

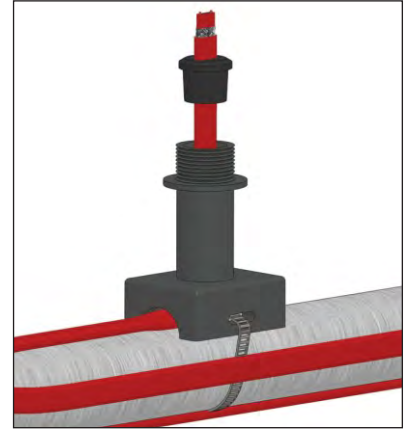

3. Using wire cutters trim exposed grounding braid away from the end of the cable.

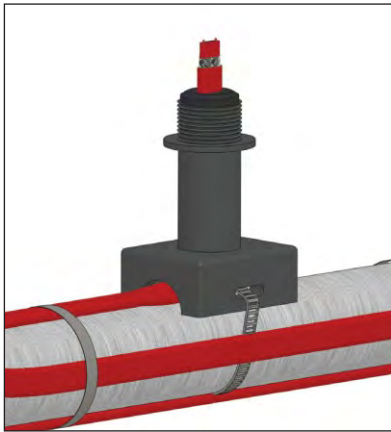

4. Adjust cable leaving 1" past the end of the grommet and insert the grommet into the pipe standoff. Attach extra cable to pipe as shown.

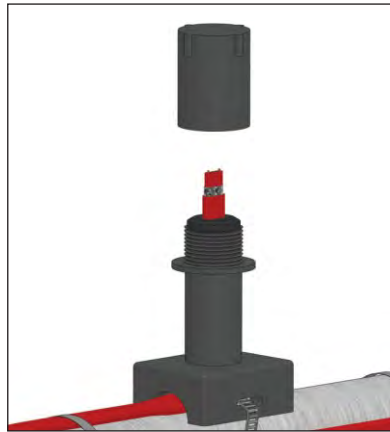

5. Slide end cap over cable. Grommet should be placed inside pipe standoff.

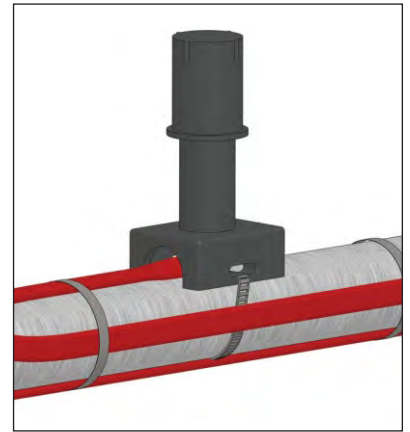

6. Tighten end cap until it bottoms out on pipe standoff.

**TRASOR**

**Electrical Heat Trace Systems**

800-324-1551

[www.trasor.com](http://www.trasor.com)