

SIT-6E Pavement Mounted Snow and Ice Sensor

BENEFITS

- Reliable snow melting
- Minimum energy cost
- Long trouble-free life

FEATURES

- Control based upon pavement conditions
- Rugged construction
- Simple installation
- Low voltage operation

DESCRIPTION

The SIT-6E, which replaces the SIT-5E, reliably detects snow and ice conditions on pavement surfaces. This ensures that deicing heaters operate only while needed, which minimizes energy costs without sacrificing snow melting effectiveness. A built-in hold-on timer keeps heaters operating for an hour after snow stops to help ensure complete snow melting.

The SIT-6E senses snow as moisture detected between -30° to 38°F (-34.4° to 3.33°C). Operation in the 32° to 38°F (0° to 3.3°C) temperature range eliminates otherwise slow melting. The SIT-6E accurately measures pavement temperature by compensating for its internal heating. This eliminates the cost and complexity of a separate pavement temperature sensor. For improved efficiency, the SIT-6E mounts closely to the deicing heaters to ensure that pavement and sensor become dry at about the same time.

The new mounting system helps align the SIT-6E with the pavement surface. Six available conduit locations add to installation flexibility and simplicity. The sensor subassembly is field replaceable without disturbing the pavement. The SIT-6E is a NEC Class 2 low voltage device which simplifies installation.

Only brass, epoxy, and stainless steel are exposed to the pavement surface. Precision machining gives the SIT-6E a handsome appearance that will please the building owner, engineer, and architect.

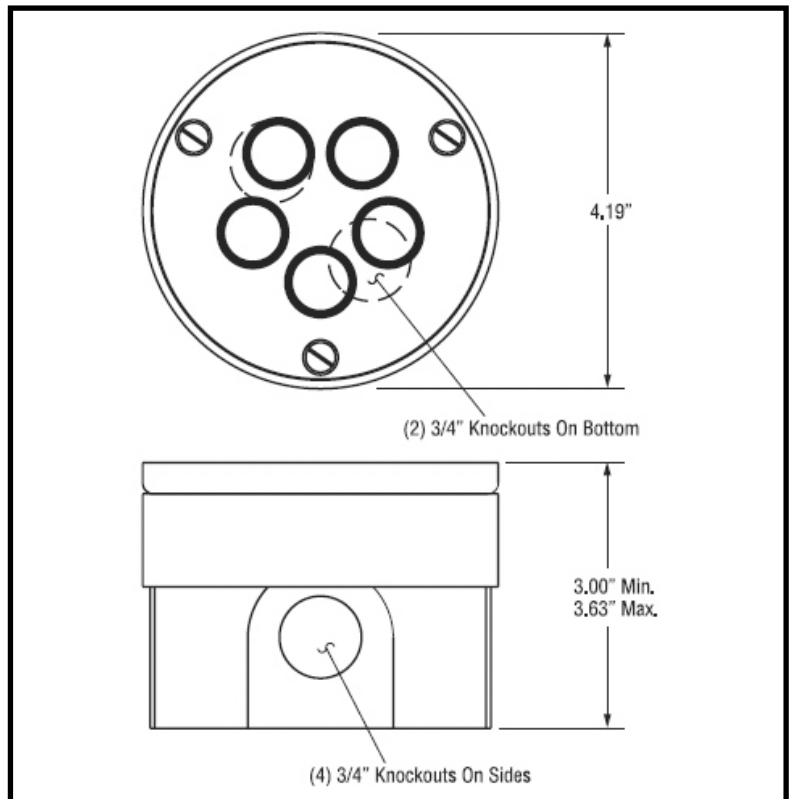

SIT-6E Pavement Mounted Snow and Ice Sensor

INSTALLATION

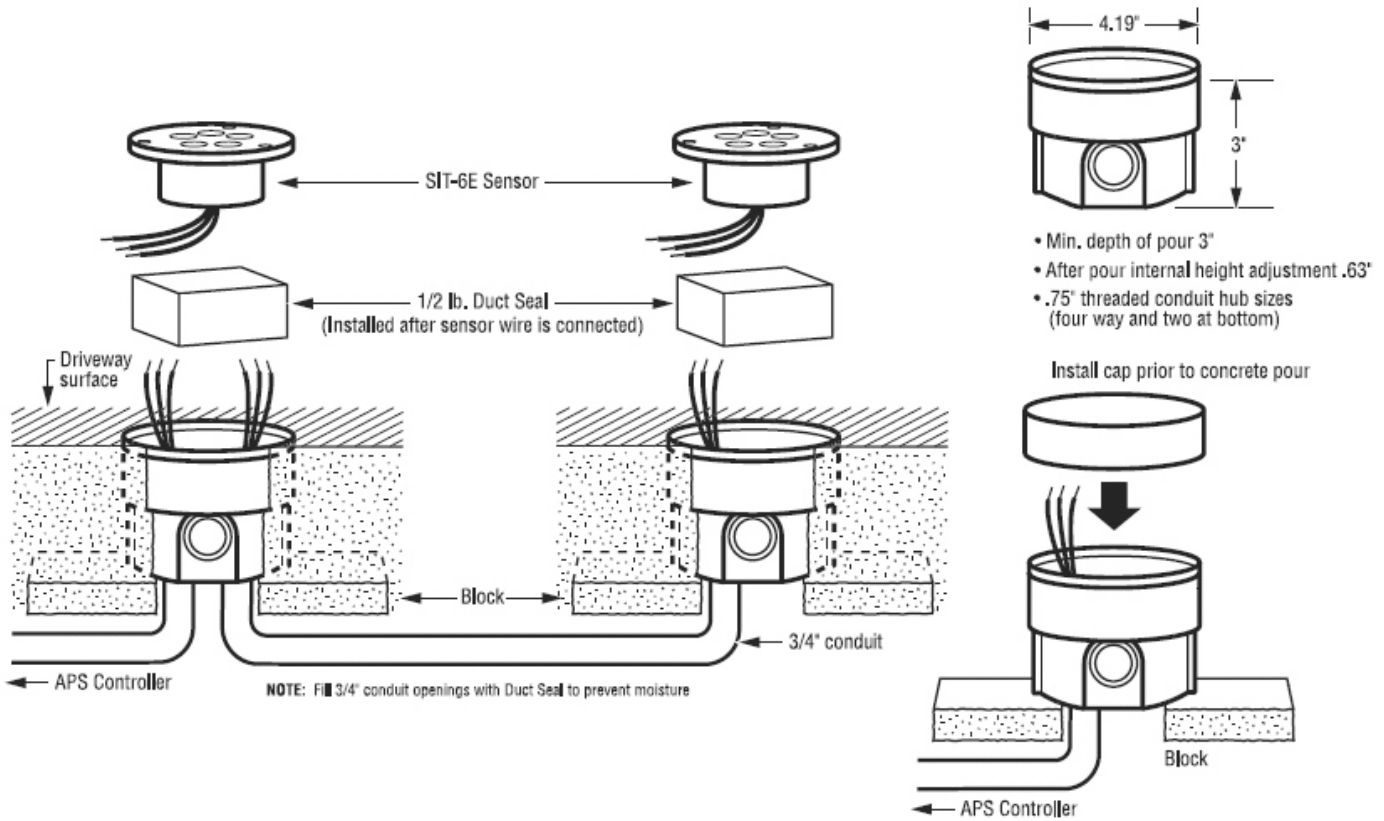

ORDERING INFORMATION

Order Number	Description
20756	SIT-6E Pavement-Mounted Snow and Ice Sensor
20755	Replacement SIT-6E Sensor Subassembly*
20879	100' Spool of 3-Conductor Sensor Extension Wire**
20877	250' Spool of 3-Conductor Sensor Extension Wire**
20878	500' Spool of 3-Conductor Sensor Extension Wire**
20760	Pavement Mounted Junction Box**

* Replacement Part

** Accessory

LIMITED WARRANTY

Trasor's one year limited warranty covering defects in workmanship and materials applies. Contact Customer Service for complete warranty information.