

Installation Instructions

Type USL Signal Light Kit for Self-Regulating & Constant Wattage Heating Cables

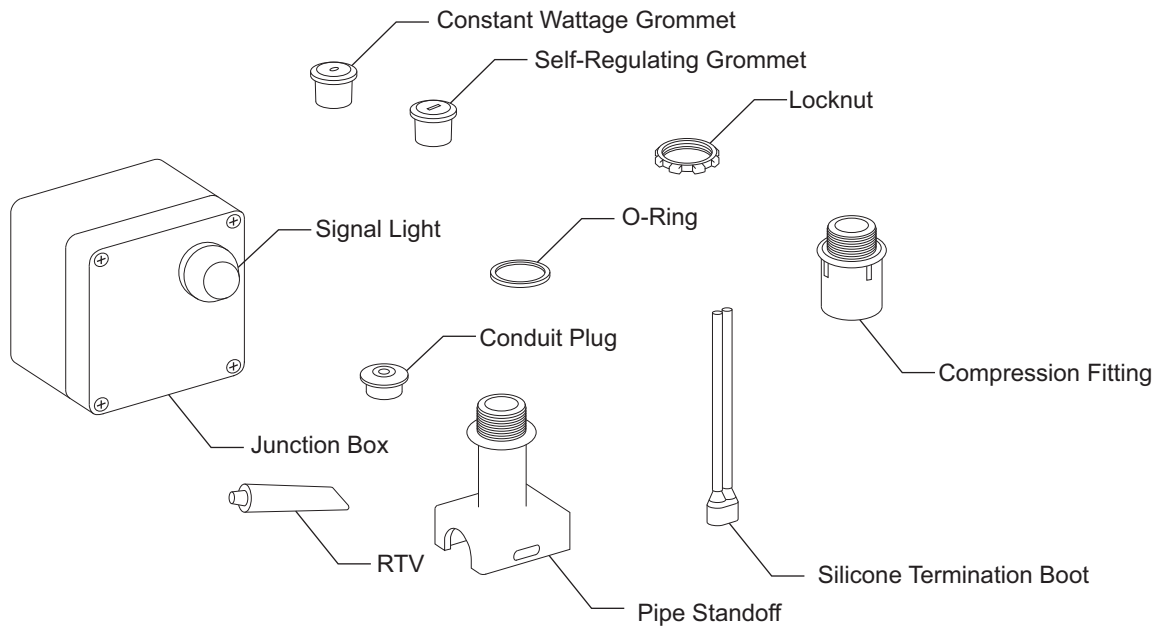

Qty	Description
1	Junction box
1	Compression fitting
1	Locknut
1	Silicone termination boot
1	Pipe standoff
1	RTV
1	O-ring
1	Self-Regulating cable grommet
1	Constant wattage cable grommet

General

The USL signal light kit is used for electrical termination of self-regulating and constant wattage cables. Each kit contains the terminations needed to make all electrical connections.

INSTALLATION

⚠ WARNING

HAZARD OF ELECTRIC SHOCK. Disconnect all power before starting. All installations must be effectively grounded in accordance with the National Electrical Code to eliminate shock hazard.

⚠ WARNING

Turn off power before removing end cap at all times.

⚠ WARNING

Users should install adequate controls and safety devices with their electric heating equipment. Where the consequences of failure may be severe, back-up controls are essential. Although the safety of the installation is responsibility of the user, Trasor will be glad to assist in making equipment recommendations.

Braid only cable instructions SRL-C, SRF-C, SRM/E-C, CWM-C

1. Push braiding back from the end of the cable. 11 inches from cable end create a bulge. At the bulge, separate the braid to make an opening.

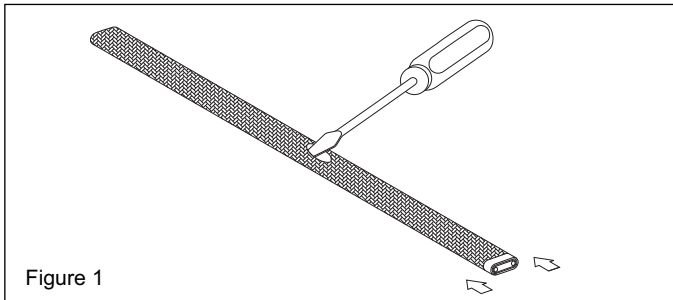

Figure 1

2. While bending the heating cable, work the cable through the braid opening. Pull the braid tight.

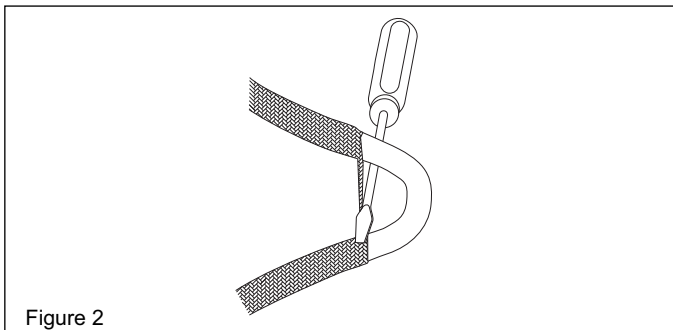

Figure 2

3. Insert cable through pipe standoff and grommet as shown. Leave braid outside of pipe standoff for future connection to ground. Attach standoff.

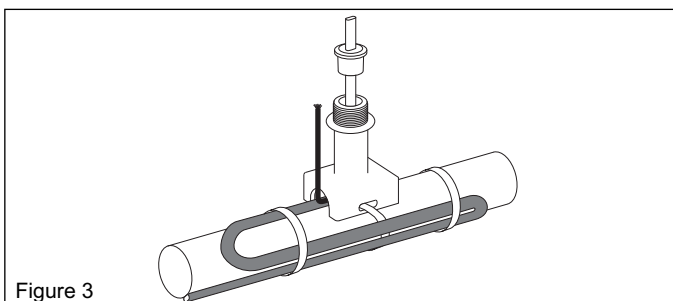

Figure 3

4. Score the inner insulation 7 inches from the end. Lightly cut the inner jacket up the center to end of heating cable and remove the inner jacket from the cable.

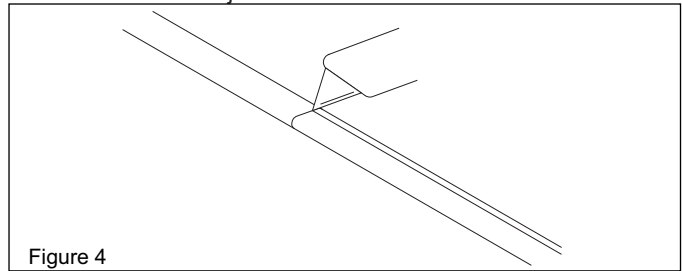

Figure 4

5. Shave the core material from the outside of each bus wire. *Skip this step if using CWM-C constant wattage cable.

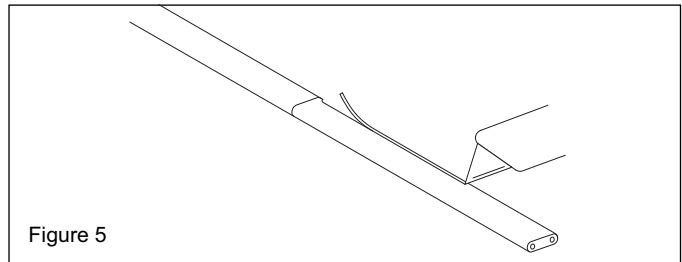

Figure 5

6. Starting at the end of the heating cable, using needle nose pliers or a knife pull each bus wire away from the core material. *Separate CWM-C leads and strip 1/4" from each leadwire.

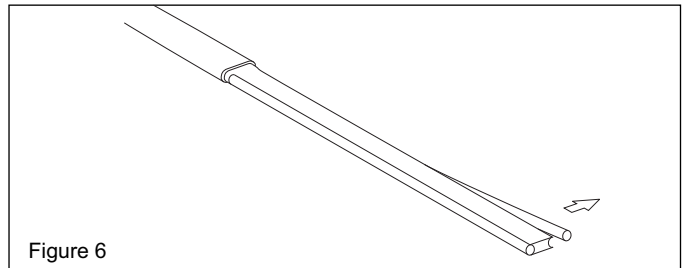

Figure 6

7. Remove the exposed core material and cut 1/4" off the end of each bus wire. *Skip this step if using CWM-C constant wattage cable.

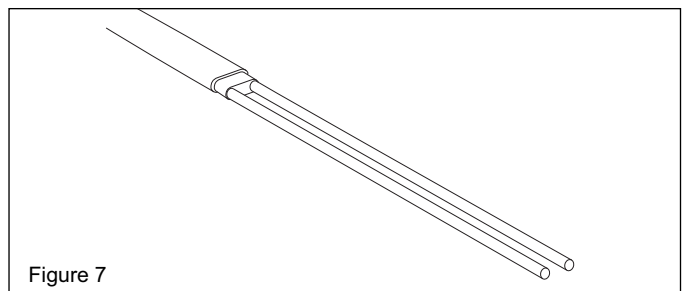

Figure 7

8. Liberally apply RTV over the exposed matrix and leads. Push the rubber boot over the heating cable. Trim lead ends as needed. *Boot is not needed when using CWM-C constant wattage cable.

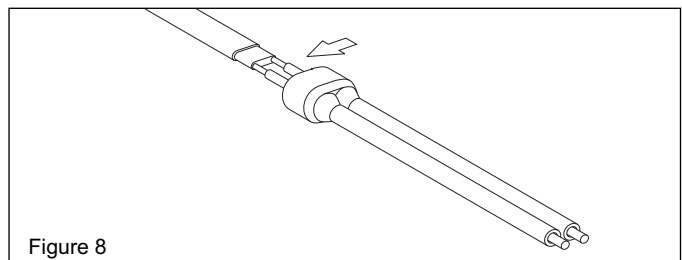

Figure 8

INSTALLATION

- Slide compression fitting over cable. Grommet should be placed inside pipe standoff. Termination boot should be spaced 1/2" from sealing grommet. Tighten compression fitting until it bottoms out against pipe standoff.

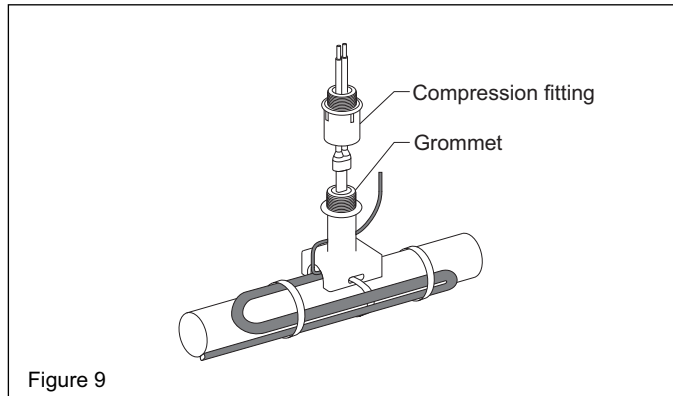

Figure 9

- Assemble junction box to compression fitting as shown. Tighten locknut until the junction box bottoms out against the lip of the compression fitting.

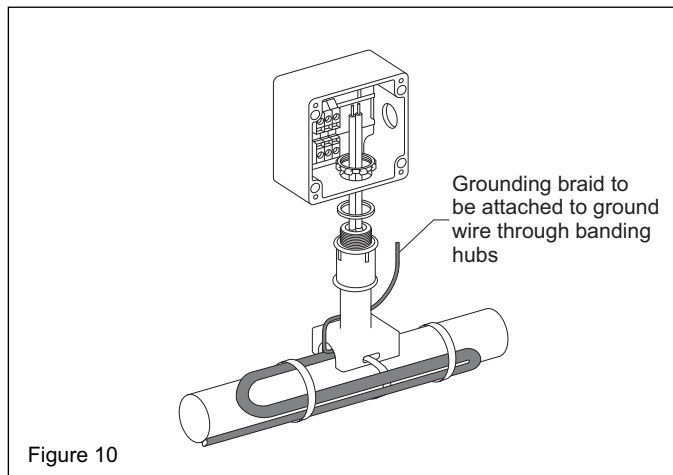

Figure 10

- If USL is being used as a power connection attach conduit hub (Trasor CCH-2 or equivalent not included) to side entry. If USL is being used as an end seal attach conduit plug to side entry. Use a flat head screwdriver to release the terminal spring clamps and insert cable leads and grounding braid. Supply power electrical connections should be brought to terminal as shown. Attach junction box cover to seal enclosure.

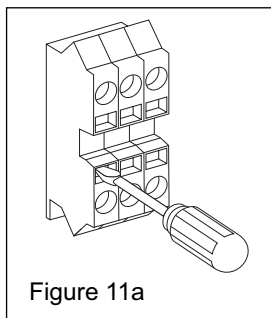

Figure 11a

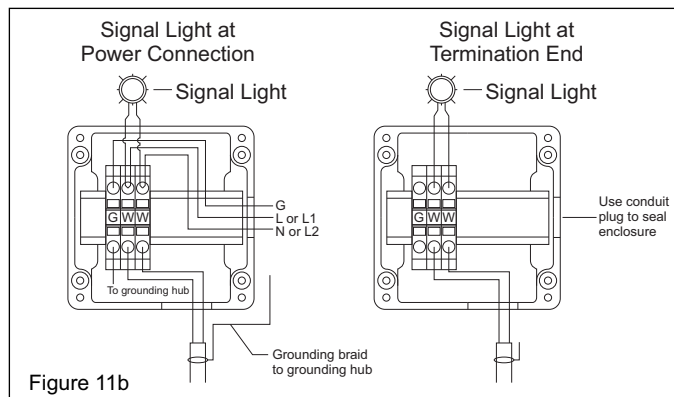

Figure 11b

Overjacketed cable instructions for SRL-CR, SRL-CT, SRF-CR, SRM/E-CT. CWM-CT cable instructions denoted by *

- Insert heating cable through pipe standoff and grommet as shown. 8 inches of cable should extend past the grommet. Strap pipe standoff to pipe with pipe strap (Trasor type PS not included) and attach extra cable to pipe as appropriate. For pipes smaller than 1-1/2" diameter a small pipe adapter (Trasor model SPA not included) is required.

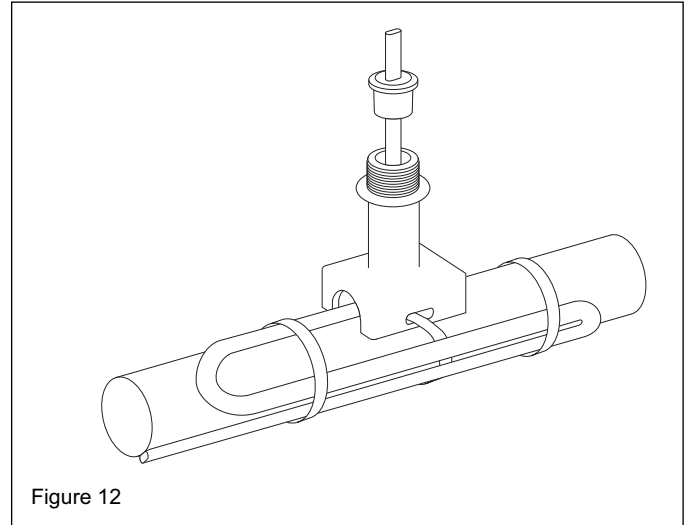

Figure 12

- Score the outer insulation 7 inches from the end of the cable. Lightly cut the outer jacket up the center to the end of heating cable and remove the outer jacket from the cable. **WARNING: DO NOT CUT METAL BRAID.**

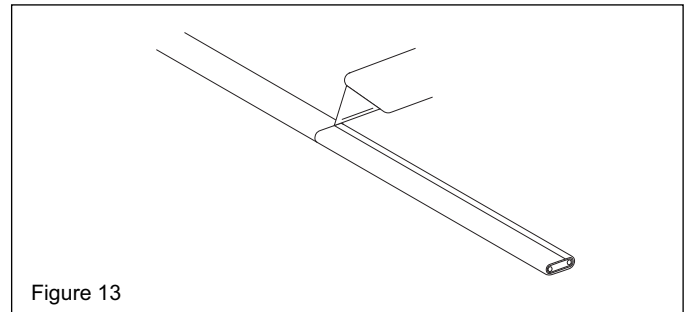

Figure 13

- Move braid back toward the overjacket, creating a bulge. At the bulge, separate the braid to make an opening.

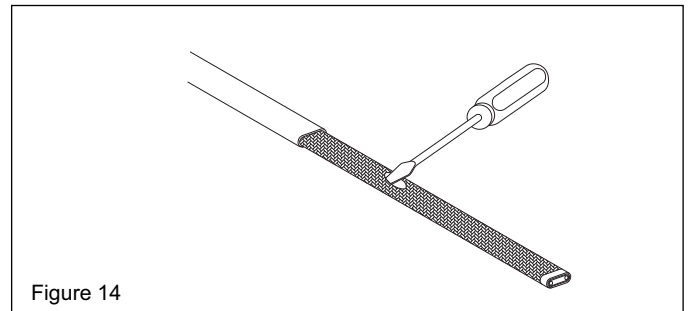
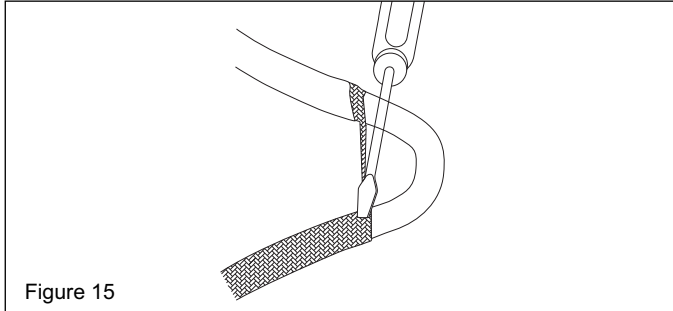

Figure 14

INSTALLATION

4. While bending the heating cable, work the cable through the braid opening. Pull the braid tight.



5. Score the inner insulation 6 inches from the end. Lightly cut the inner jacket up the center to end of heating cable and remove the inner jacket from the cable.

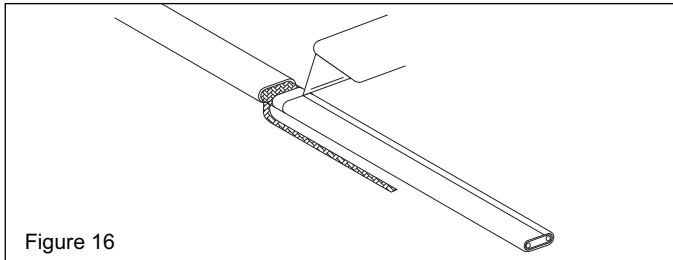

6. Shave the core material from the outside of each bus wire.
*Skip this step if using CWM-C constant wattage cable

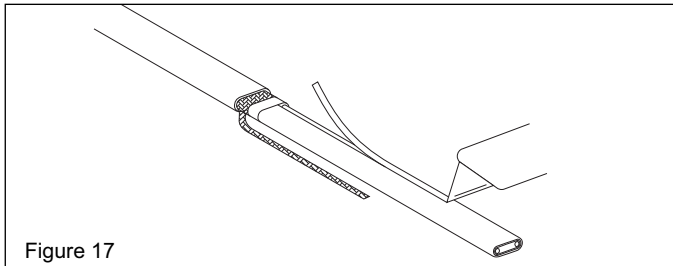

7. Starting at the end of the heating cable, using needle nose pliers or a knife pull each bus wire away from the core material. *Separate CWM-C leads and strip 1/4" from each leadwire.

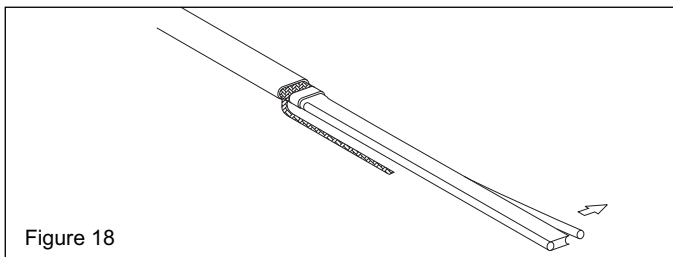

8. Remove the exposed core material and cut 1/4" of the end of each bus wire. *Skip this step if using CWM-C constant wattage cable

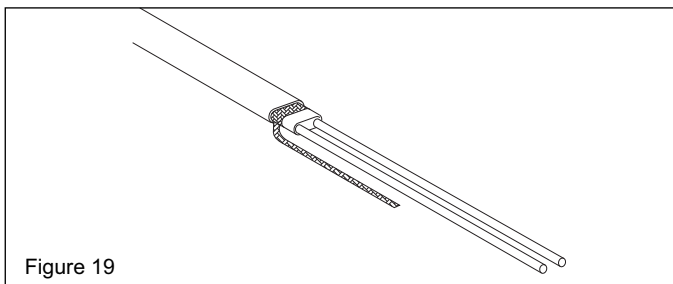

9. Liberally apply RTV over the exposed matrix and leads. Push the rubber boot over the heating cable. Trim lead ends as needed. *Boot is not needed when using CWM-C constant wattage cable.

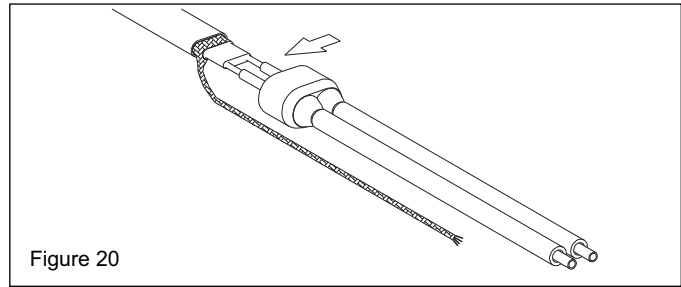

10. Slide compression fitting over cable. Grommet should be placed inside pipe standoff. Termination boot should be spaced 1/2" from sealing grommet.

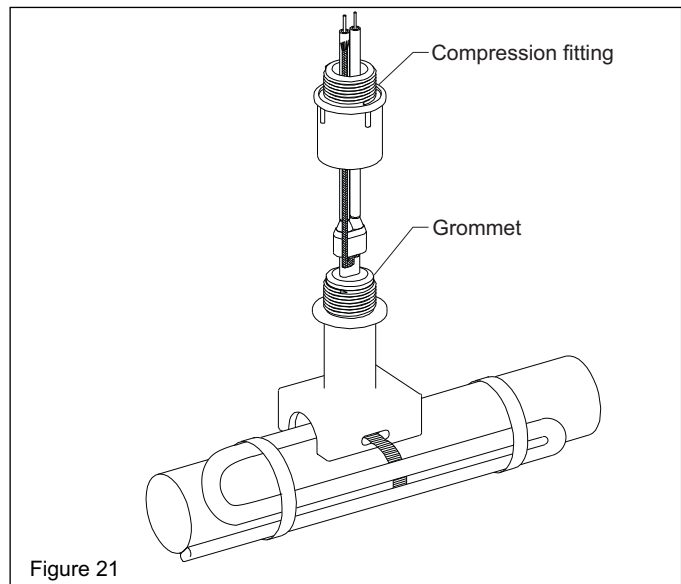

11. Assemble junction box to compression fitting as shown. Tighten locknut until the junction box bottoms out against the lip of the compression fitting.

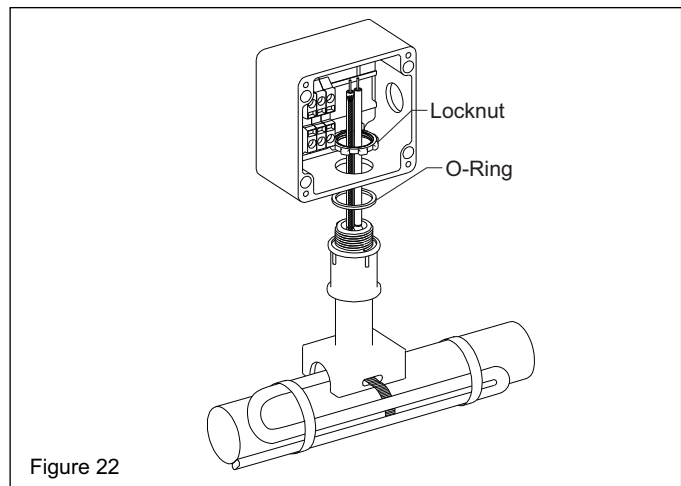

INSTALLATION

12. If USL is being used as a power connection attach conduit hub (Trasor CCH-2 or equivalent not included) to side entry. If USL is being used as an end seal attach conduit plug to side entry. Use a flat head screwdriver to release the terminal spring clamps and insert cable leads and grounding braid. Supply power electrical connections should be brought to terminal as shown. Attach junction box cover to seal enclosure.

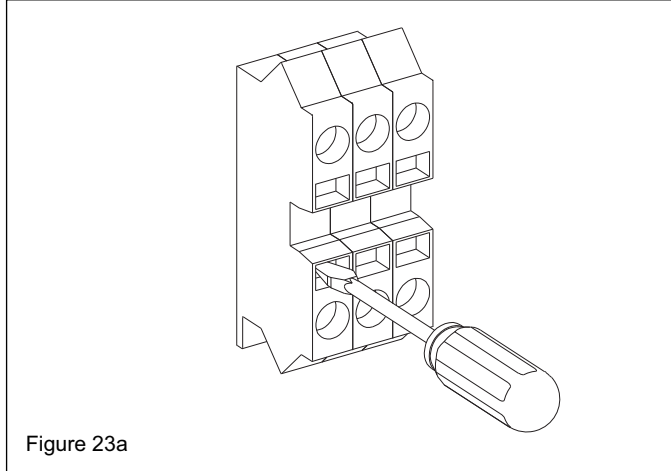

Figure 23a

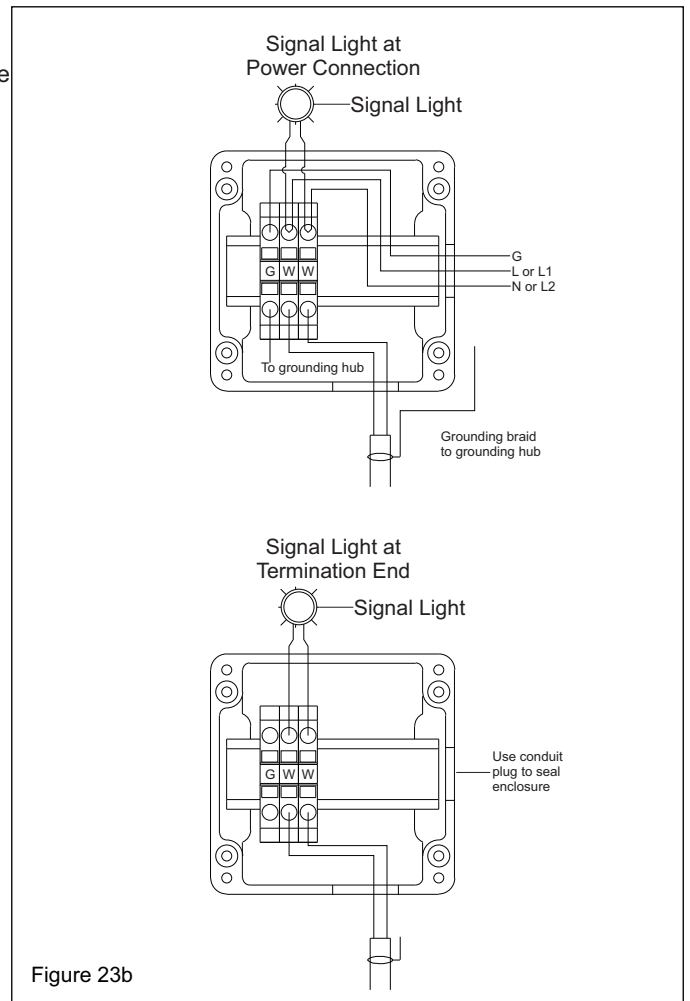

Figure 23b

TRASOR

Electrical Heat Trace Systems

800-324-1551

www.trasor.com