

FPT 130 Single-Point Freeze Protection Heat-Trace Control

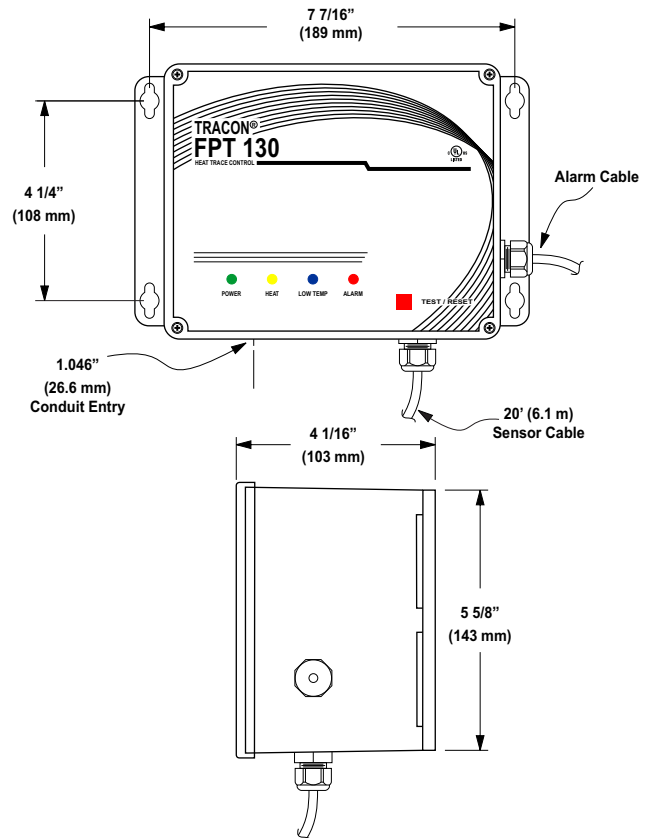
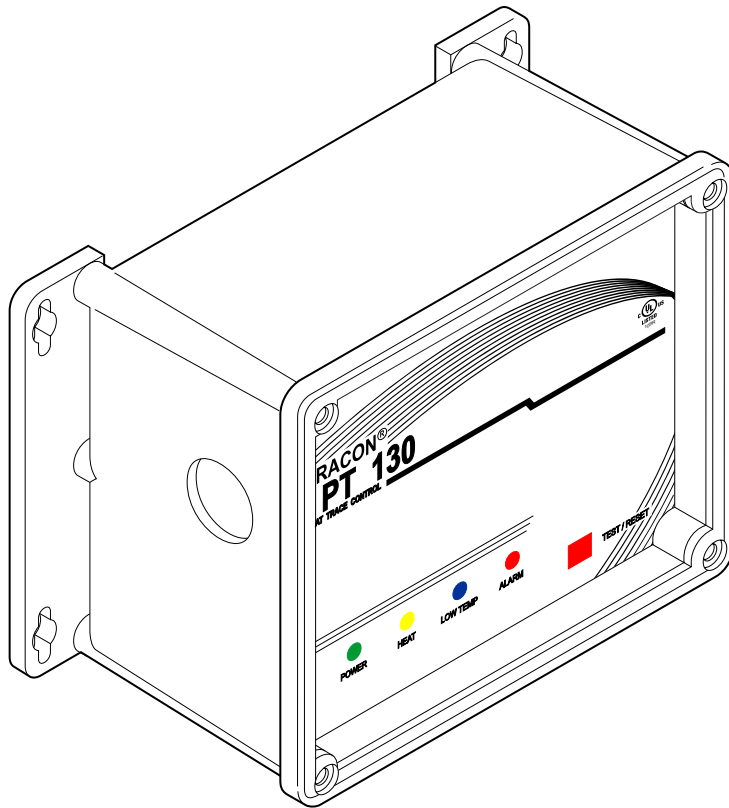

The FPT 130 Heat-Trace Control is a single-point microprocessor-based heat-trace control thermostat. It is ideal for applications which require Ground-Fault Equipment Protection (GFEP). Ideal uses include freeze protection, and other temperature monitoring and control applications.

The FPT 130 Heat-Trace Control operates from the heater's power source. A universal power supply allows the FPT 130 to operate from 100 VAC to 277 VAC, and control a resistive load up to 30 A.

Adjustable Temperature Setpoint and Alarms

The temperature setpoint is adjustable from 30 °F, 38 °F, 45 °F, or 50 °F (-1.1 °C, 3.3 °C, 7.2 °C, or 10 °C) to a tenth degree resolution.

Sensor Inputs

The FPT 130 comes with a 100K ohm thermistor temperature sensor with a 20 ft jacketed cable. The included sensor has an operating range of -40 °F to 230 °F (-40 °C to 110 °C).

Precision Monitoring and Control

The FPT 130 monitors temperature, load current, and ground leakage current. Alarms include low temperature, low load current, ground fault, sensor fault, internal fault, and power fail. These alarms are pre-set and easy to observe from the front panel.

Ground-Fault Equipment Protection

The FPT 130 Heat-Trace Control includes integral GFEP. This eliminates the extra expenses associated with having to provide separate GFEP components in the circuit panel.

The FPT 130 normally disconnects power immediately when ground fault current exceeds 30 mA. If it is set to Fire Protect mode, for critical fire protection systems, then it will generate the alarm but power will be maintained to prevent freezing.

Automatic GFEP Circuit Self-Test

To ensure continued safe operation, the FPT 130 performs a self-test of the GFEP circuit when power is first applied, along with a load ground fault test, and this test repeats every 24 hours while power is applied if the load has not been energized.

Specifications

General

Certifications UL 60730–1, UL 1053, CSA E60730–1:13

Environmental

Area of use Nonhazardous locations
Operating temperature –40 °F to 131 °F (–40 °C to 55 °C)

Enclosure

Dimensions 8-1/8" (W) x 5-1/2" (H) x 4-3/8" (D)
207 mm (W) x 140 mm (H) x 112 mm (D)

Ingress protection NEMA 4X, IP66

Cover attachment Polycarbonate cover, plastic screws

Cable entries Two liquid-tight cable glands installed for sensor and alarm leads, cable diameter 0.08" to 0.24" (2 mm to 6 mm) One 1.046" hole to accommodate a 3/4" conduit fitting for power wiring connection

Material Polycarbonate

Weight 2.7 lb (1.22 kg)

Mounting Wall mount with flanges

Wiring Connector Ratings

Power Barrier Strip Terminals for Line, Neutral, and Ground; use 10 AWG wires rated for at least 194 °F (90 °C)

Sensors Terminal Block, rising cage clamp, 12–28 AWG leads

Alarm relay Terminal Block, rising cage clamp, 12–28 AWG leads

Parameter Settings

Temperature setpoints 30 °F, 38 °F, 45 °F, or 50 °F (–1.1 °C, 3.3 °C, 7.2 °C, or 10 °C)

Low-temperature threshold 2 °F (1 °C) below setpoint

Low-current alarm threshold 0.1 A

Low-current alarm delay 5 s

Ground fault limit current 30 mA

Self-test interval 24 h

User Interfaces

Pushbutton Test / Reset
DIP switches Temperature setpoint

Thermistor fault mode

Fire protection mode

Indicators

Status indicator Power to the unit (Green solid)
Calibration error (Green blinking)
Call for heat (Yellow solid)
Low current alarm (Yellow blinking)
Stuck relay (Yellow blinking fast)
Low temperature (Blue solid)
Sensor fault (Blue blinking)
Ground fault (Red solid)
GFEP circuit failure (Red blinking)

Summary alarm relay reporting Low load current
High ground fault current
Sensor fault
Internal fault

Control Ratings

Temperature accuracy +/- 2 °F (1 °C)

Temperature Sensors

Temperature input (Included) Thermistor, 100k ohms at 25 °C, range –40 °F to 230 °F (–40 °C to 110 °C), 20 ft (6.1 m) Lead (25076)

GFEP (Ground–Fault Equipment Protection)

Threshold 30 mA

Automatic self-test range Verifies GFEP functionality every 24 h and when the load is turned on

Power

Supply voltage 100 – 277 VAC 50/60 Hz

Controller power consumption 5 W maximum, 2 W idle

Load rating 30 A 2-pole, 100 – 277 VAC resistive

Specifications are at 77 °F (25 °C) unless otherwise stated and are subject to change without notice.

LIMITED WARRANTY

Trasor's one year limited warranty covering defects in workmanship and materials applies. Contact Customer Service for complete warranty information.