

## E55-400 High Temperature Line Sensing Thermostat

The E55-400 is a remote line sensing thermostat for controlling heat trace systems in ordinary and corrosive environments. It is ideal for process temperature control up to 400 °F

### Enclosure

Nema-4X  
Die Cast Aluminum with Epoxy  
Powder Coating

### Adjustable Range

50 to 400 °F (10 to 204 °C)

### Bulb Temperature Limits

-40 to 600 °F (-40 to 315 °C)

### Capillary

10' 304 Stainless Steel

### Switch

SPDT, 22 Amps @  
120/240/480 VAC  
1,000,000 cycles

### Accuracy

+/- 1% of range

### Differential

Typically 1% of range

### Weight

1 lb

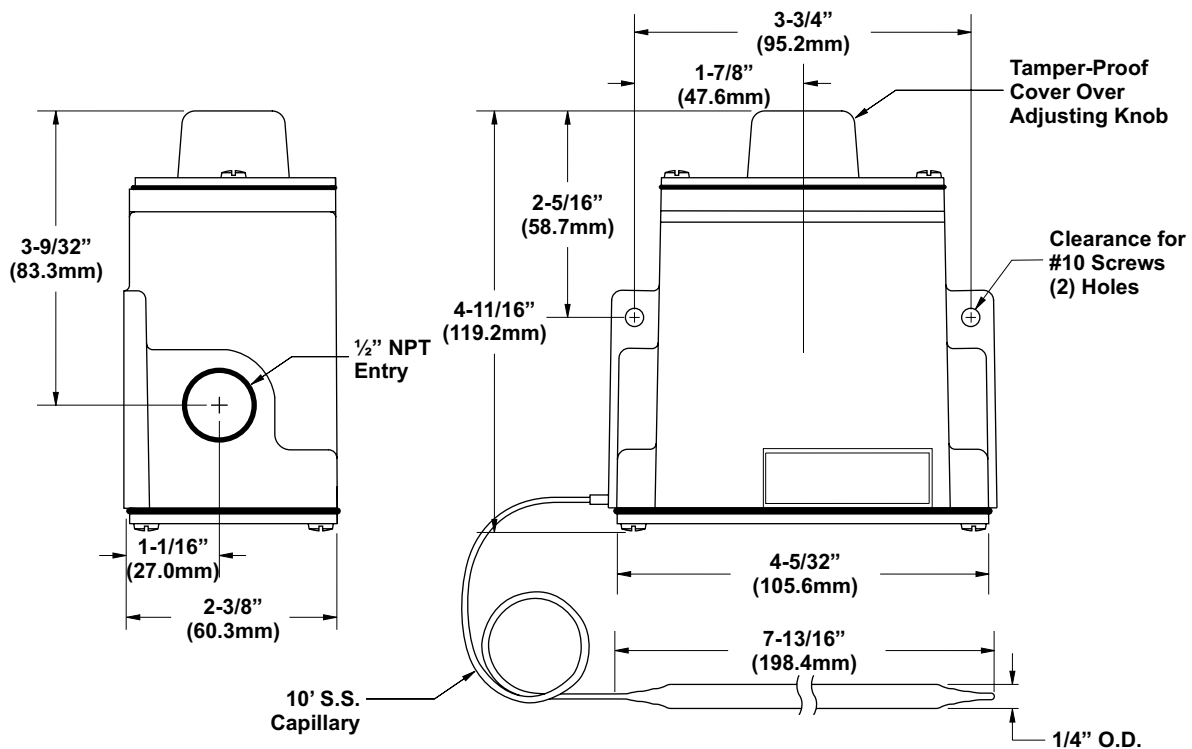

## Installation

### Notes:

- Securely mount thermostat near the start of the heat trace circuit.
- Connect control wiring. Wire according to all applicable codes.
- Low point drains are recommended on conduit piping.
- Select set point and secure cover to protect from weather.
- Route capillary so it is protected from damage. Do not kink.
- Mount bulb a minimum of 90° degrees from heating cable and locate away from heat sinks (valves and supports).

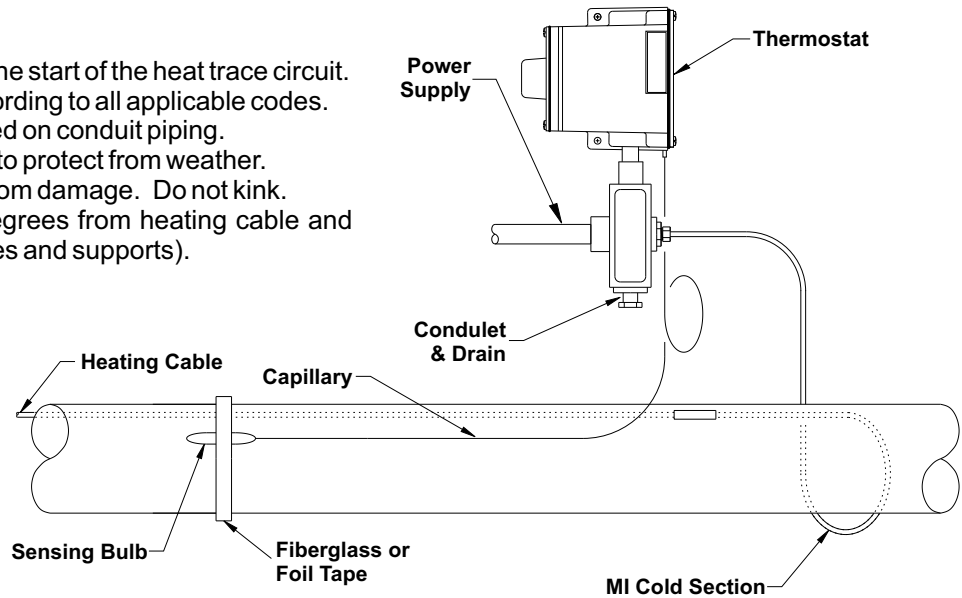
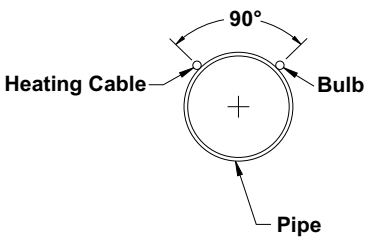

## Annual Maintenance

Spray a coat of lubricant and rust preventative such as CRC Stor & Lube on electrical connections and dial stem. Trasor part number: ASK-10165.

## Wiring Diagram

The normally closed contacts are closed when bulb temperature is below set point.

Contacts Rated:  
22 Amps @ 120/240/480 VAC

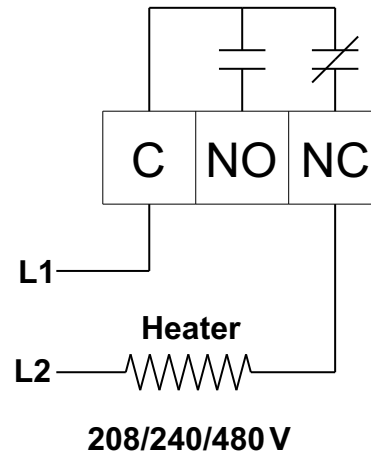
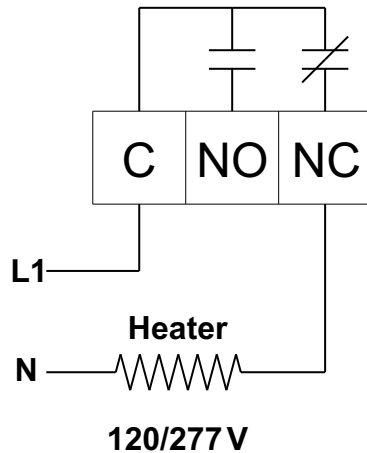

All information is believed to be reliable. Users should independently evaluate the suitability of each product for their application. There are no warranties given except such expressed warranties offered in the sale of the product. In no instance or event shall Trasor Corporation be liable for any consequential, incidental or indirect damages arising from the use of this product. Trasor Corporation has no obligations to notify any person or organization of any changes to the specification or product.